



# MANUAL: HAND HELD AUTOMATIC PRESSURE CONTROL NOZZLES

## ULTIMATIC, MID-MATIC & HANDLINE

### INSTRUCTIONS FOR INSTALLATION, SAFE OPERATION AND MAINTENANCE

#### **⚠ WARNING**

Understand manual before use. Operation of this device without understanding the manual and receiving proper training is a misuse of this equipment. Obtain safety information at [www.tft.com/serial-number](http://www.tft.com/serial-number)

This instruction manual is intended to familiarize firefighters and maintenance personnel with the operation, servicing and safety procedures associated with the Ultimatic, Mid-Matic and Handline fire fighting nozzles.

This manual should be kept available to all operating and maintenance personnel.

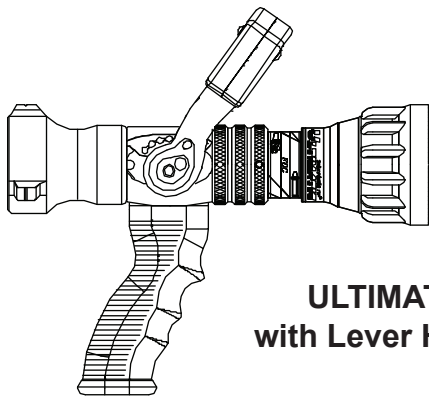

**ULTIMATIC  
with Lever Handle**

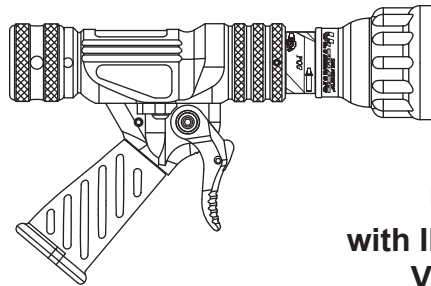

**ULTIMATIC  
with IMPULSE Trigger  
Valve System**

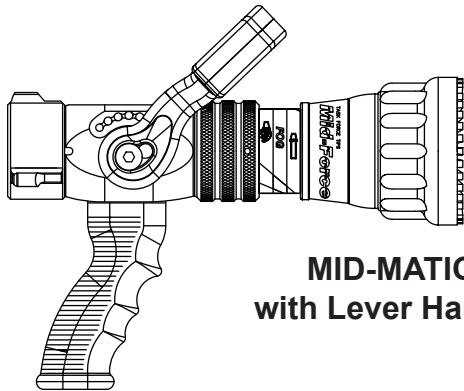

**MID-MATIC  
with Lever Handle**

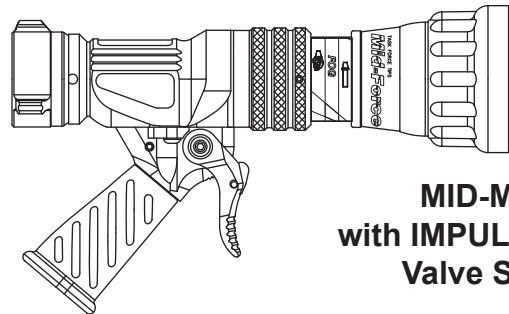

**MID-MATIC  
with IMPULSE Trigger  
Valve System**

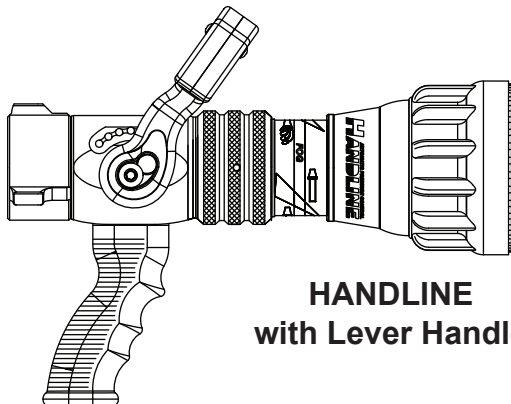

**HANDLINE  
with Lever Handle**

**TASK FORCE TIPS, INC.**  
MADE IN USA • [www.tft.com](http://www.tft.com)

3701 Innovation Way, Valparaiso, IN 46383-9327 USA  
800-348-2686 • 219-462-6161 • Fax 219-464-7155

## Table Of Contents

- 1.0 MEANING OF SAFETY SIGNAL WORDS
- 2.0 SAFETY
- 3.0 GENERAL INFORMATION
  - 3.1 VARIOUS MODELS AND TERMS
  - 3.2 SPECIFICATIONS
    - 3.2.1 MECHANICAL
  - 3.3 NOZZLE COUPLINGS
  - 3.4 USE WITH SALT WATER
- 4.0 FLOW CHARACTERISTICS
  - 4.1 NOZZLE FLOW CHARTS
  - 4.2 REACH AND TRAJECTORY
  - 4.3 ULTIMATIC INITIAL OPENING ADJUSTMENT OPTION
- 5.0 NOZZLE CONTROLS
  - 5.1 FLOW CONTROL
    - 5.1.1 LEVER TYPE FLOW CONTROL
    - 5.1.2 TIP ONLY
    - 5.1.3 BALL SHUT-OFF
    - 5.1.4 TWIST SHUT-OFF
    - 5.1.5 IMPULSE TRIGGER FLOW CONTROL
      - 5.1.5.1 IMPULSE TRIGGER LOCK
      - 5.1.5.2 IMPULSE TRIGGER CLOSING SPEED ADJUSTMENT
      - 5.1.5.3 NORMAL OPERATING POSITION
  - 5.2 PATTERN AND FLUSH CONTROL ADJUSTMENT
    - 5.2.1 PATTERN CONTROL
    - 5.2.2 FLUSH CONTROL
- 6.0 USE WITH FOAM
  - 6.1 FOAM ASPIRATING ATTACHMENTS
- 7.0 USE OF NOZZLES
- 8.0 APPROVALS
- 9.0 COLOR CODED VALVE HANDLE AND PISTOL GRIP
  - 9.1 IMPULSE TRIGGER VALVE SYSTEM NOZZLE COLORED PISTOL GRIPS
- 10.0 WARRANTY
- 11.0 MAINTENANCE
  - 11.1 FIELD LUBRICATION
  - 11.2 IMPULSE TRIGGER VALVE LUBRICATION
  - 11.3 SERVICE TESTING
    - 11.3.1 HYDROSTATIC TESTING
    - 11.3.2 FLOW TESTING
    - 11.3.3 RECORDS
  - 11.4 REPAIR
- 12.0 OPERATION and INSPECTION CHECKLIST



### PERSONAL RESPONSIBILITY CODE

The member companies of FEMSA that provide emergency response equipment and services want responders to know and understand the following:

1. Firefighting and Emergency Response are inherently dangerous activities requiring proper training in their hazards and the use of extreme caution at all times.
2. It is your responsibility to read and understand any user's instructions, including purpose and limitations, provided with any piece of equipment you may be called upon to use.
3. It is your responsibility to know that you have been properly trained in Firefighting and /or Emergency Response and in the use, precautions, and care of any equipment you may be called upon to use.
4. It is your responsibility to be in proper physical condition and to maintain the personal skill level required to operate any equipment you may be called upon to use.
5. It is your responsibility to know that your equipment is in operable condition and has been maintained in accordance with the manufacturer's instructions.
6. Failure to follow these guidelines may result in death, burns or other severe injury.



Fire and Emergency Manufacturers and Service Association  
P.O. Box 147, Lynnfield, MA 01940 • www.FEMSA.org

## 1.0 MEANING OF SAFETY SIGNAL WORDS

A safety related message is identified by a safety alert symbol and a signal word to indicate the level of risk involved with a particular hazard. Per ANSI standard Z535.6-2011, the definitions of the four signal words are as follows:



**DANGER** indicates a hazardous situation which, if not avoided, will result in death or serious injury.



**WARNING** indicates a hazardous situation which, if not avoided, could result in death or serious injury.



**CAUTION** indicates a potentially hazardous situation which, if not avoided, could result in minor or moderate injury.



**NOTICE** is used to address practices not related to physical injury.

SAFETY INSTRUCTIONS (or equivalent) signs indicate specific safety-related instructions of procedures

## 2.0 SAFETY



An inadequate supply of nozzle pressure and/or flow will cause an ineffective stream and can result in injury, death, or loss of property. See flow graphs or call 800-348-2686 for assistance.



The nozzle may be damaged if frozen while containing significant amounts of water. Such damage may be difficult to detect visually and can lead to possible injury or death. Any time the nozzle is subject to possible damage due to freezing, it must be tested by qualified personnel before being considered safe for use.



This equipment is intended for use by trained personnel for firefighting. Their use for other purposes may involve hazards not addressed by this manual. Seek appropriate guidance and training to reduce risk of injury.



Failure to restrain nozzle reaction can cause firefighter injury from loss of footing and/or stream protection. Nozzle reaction will vary as supply conditions change: such as opening or closing other nozzles, hose line kinks, changes in pump settings, etc. Changes in spray pattern or flushing will also affect nozzle reaction. The nozzle operator must always be prepared in the event of these changes.



If nozzle gets out of control or away from operator, retreat from nozzle immediately. Do not attempt to regain control of nozzle while flowing water. Injury from whipping can occur.



Water is a conductor of electricity. Application of water on high voltage equipment can cause injury or death by electrocution. The amount of current that may be carried back to the nozzle will depend on the following factors:

- Voltage of the line or equipment
- Distance from the nozzle to the line or equipment
- Size of the stream
- Whether the stream is solid or broken
- Purity of the water<sup>1</sup>

<sup>1</sup> The Fire Fighter and Electrical Equipment, The University of Michigan Extension Service, Fourth Printing 1983. Page 47



**Fire streams are capable of injury and damage. Do not direct water stream to cause injury or damage to persons or property.**

## 3.0 GENERAL INFORMATION

The Task Force Tips Ultimatic, Mid-Matic and Handline nozzles are designed to provide excellent performance under most fire fighting conditions. Their rugged construction is compatible with the use of fresh water (see section 3.4 for saltwater use) as well as fire fighting foam solutions. Other important operating features are:

Slide valve for excellent stream quality at all valve positions

- Quick-acting pattern control from straight stream to wide fog
- Stainless Steel Spinning Teeth or Molded Rubber for full-filled fog pattern
- “Gasket grabber” inlet screen to keep large debris from entering nozzle
- Easily flushable while flowing to clear trapped debris
- TFT’s five-year warranty and unsurpassed customer service

### 3.1 VARIOUS MODELS AND TERMS

SERIES	FLOW RANGE		NOMINAL PRESSURE		STANDARD COUPLING*
	GPM	L/min	PSI	BAR	
ULTIMATIC	10-125	40-500	100	7	1, 1-1/2 NH or 1-1/2 NPSH
ULTIMATIC and IMPULSE TRIGGER VALVE SYSTEM	10-100	40-400	75	5	1, 1-1/2 NH or 1-1/2 NPSH
MID-MATIC	70-200	260-760	100	7	1-1/2 NH
MID-MATIC and IMPULSE TRIGGER VALVE SYSTEM	70-200	260-680	75	5	1-1/2 NH
	70-180	260-680	55	3	1-1/2 NH
HANDLINE	95-300	360-1140	100	7	1-1/2 or 2-1/2 NH
	95-250	360-950	75	5	1-1/2 or 2-1/2 NH
	95-225	360-850	55	3	1-1/2 or 2-1/2 NH

\* Other threads, coupling sizes, or connector styles can be specified at time of order.

Ultimatic, Mid-Matic and Handline nozzles are available in several models. Some common models are shown in figure 1.

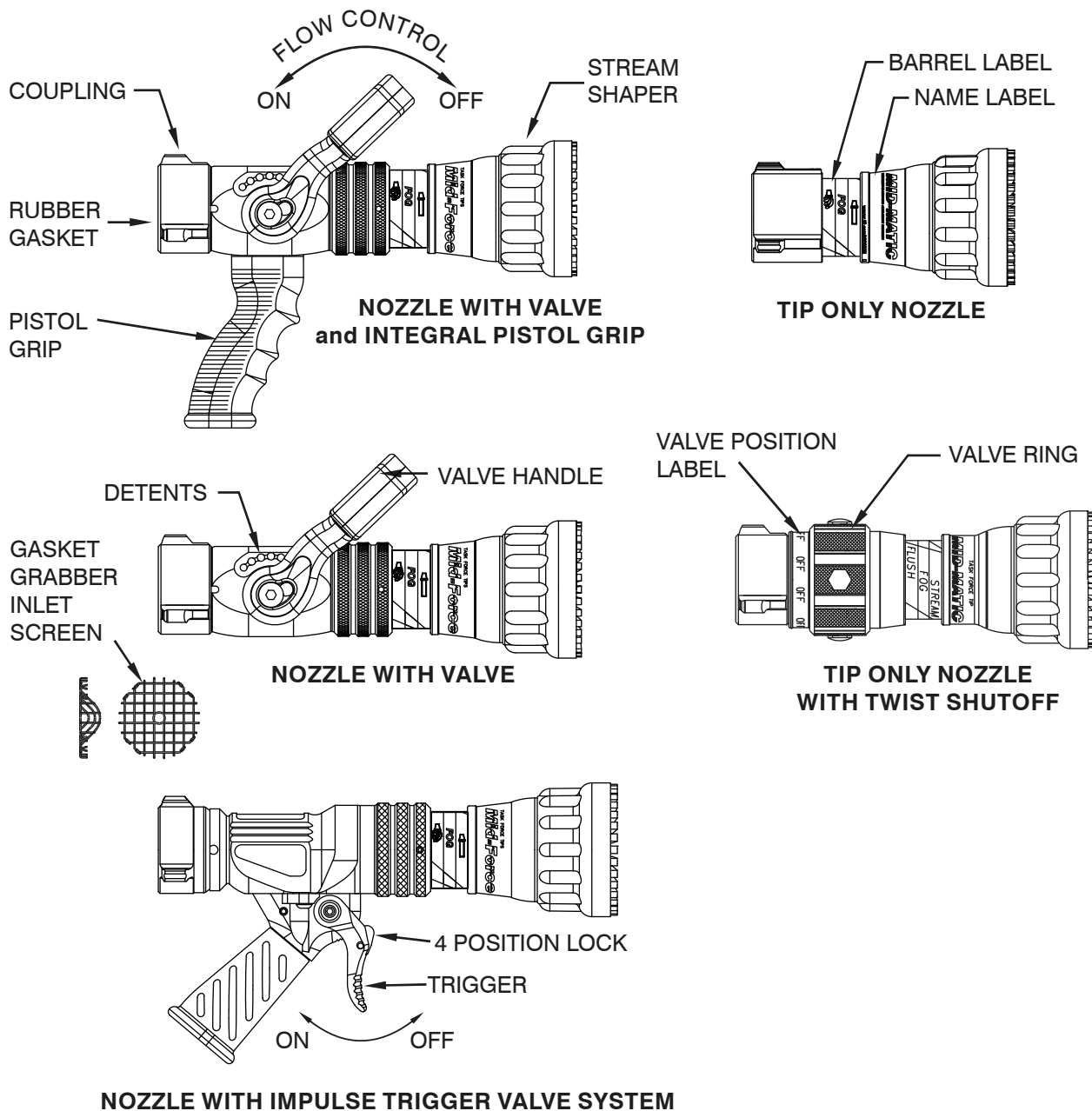

Figure 3.1 COMMON MODELS AND TERMS

### 3.2 SPECIFICATIONS

#### 3.2.1 MECHANICAL

Maximum nozzle inlet pressure with valve shutoff	Ultimatic	800 psi	55 bar
	Mid-Matic	300 psi	21 bar
	Handline	300 psi	21 bar
Operating temperature range of fluid		33 to 120° F	1 to 50° C
Storage temperature range		-40 to 150° F	-40 to 65° C
Materials used		Aluminum 6000 series hard anodized MIL8625 class 3 type 2, stainless steel 300 series, nylon 6-6, nitrile rubber	

### 3.3 NOZZLE COUPLINGS

Many inlet couplings such as NH (National Hose) or NPSH (National Pipe Straight Hose) can be specified at time of order.

**CAUTION** Nozzle must be mated to a hose line with matched threads. Mismatched or damaged threads may cause nozzle to leak or uncouple under pressure and could cause injury.

**CAUTION** Dissimilar metals coupled together can cause galvanic corrosion that can result in the inability to unscrew the threads or complete loss of thread engagement over time. Per NFPA 1962, if dissimilar metals are left coupled together an anti-corrosive lubricant should be applied to the threads. Also the coupling should be disconnected and inspected at least quarterly.

### 3.4 USE WITH SALT WATER

Use with saltwater is permissible provided nozzle is thoroughly cleaned with fresh water after each use. The service life of the nozzle may be shortened due to the effects of corrosion and is not covered under warranty.

### 4.0 FLOW CHARACTERISTICS

The graphs in figure 4 show the typical performance of ULTIMATIC, MID-MATIC, and HANDLINE nozzles.

**SPECIAL CONFIGURATIONS** If nozzles are made according to the special marking or performance requirements of the fire department then the operating characteristics may differ from the published data in this manual. Repair parts specific to each serial number may differ from those shown in the service procedure. The required parts for each serial number are available on-line by entering [www.tft.123456](http://www.tft.123456) with the numbers corresponding to the serial number engraved on the product.

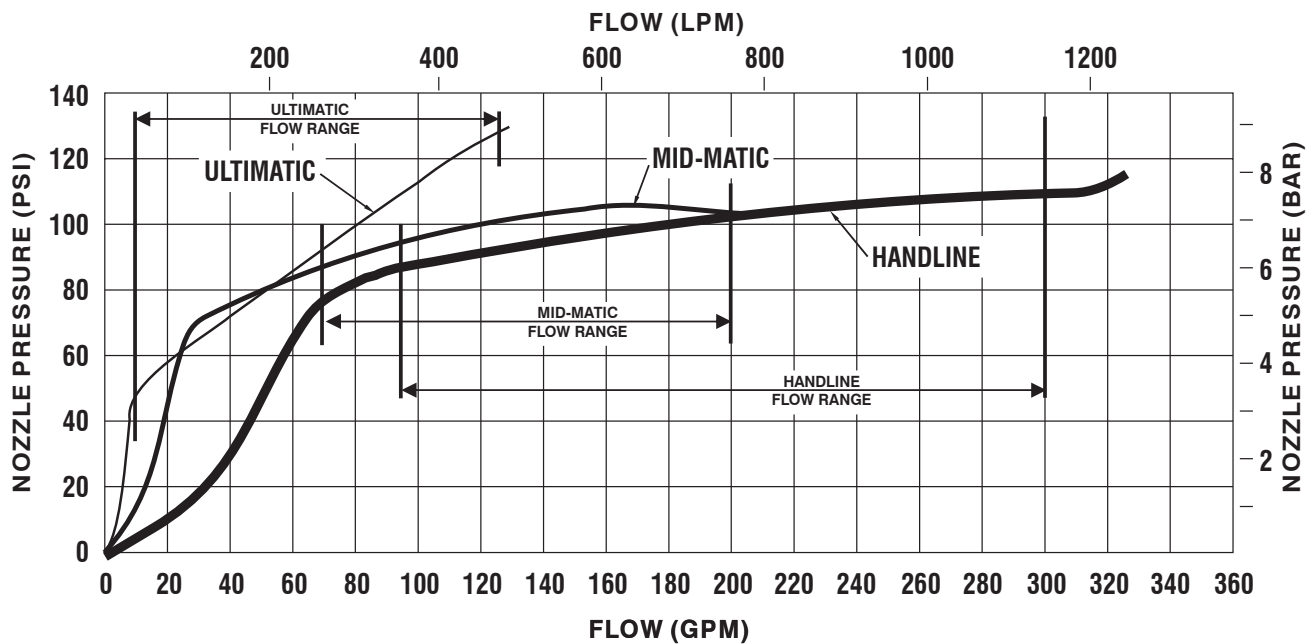

100 PSI (7 BAR) ULTIMATIC, MID-MATIC & HANDLINE

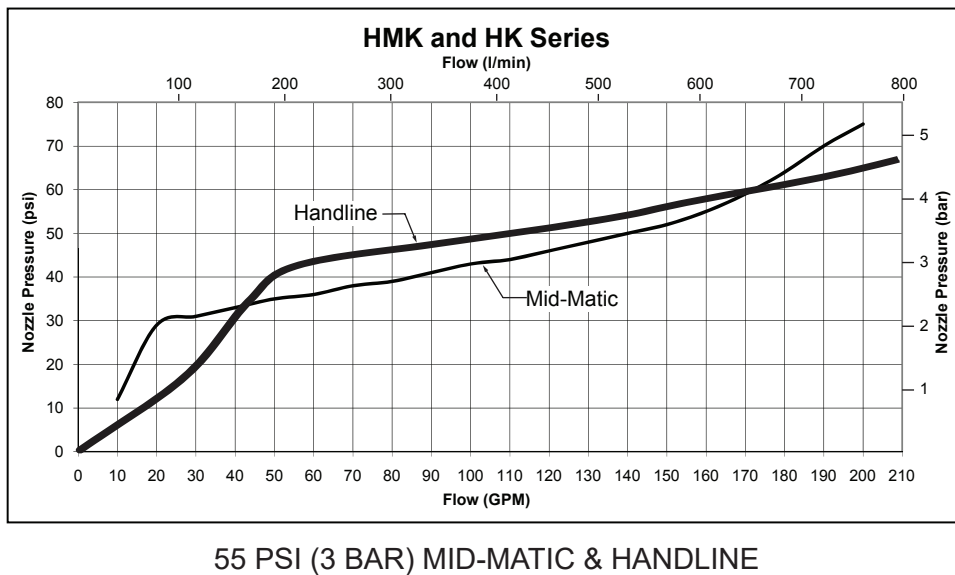
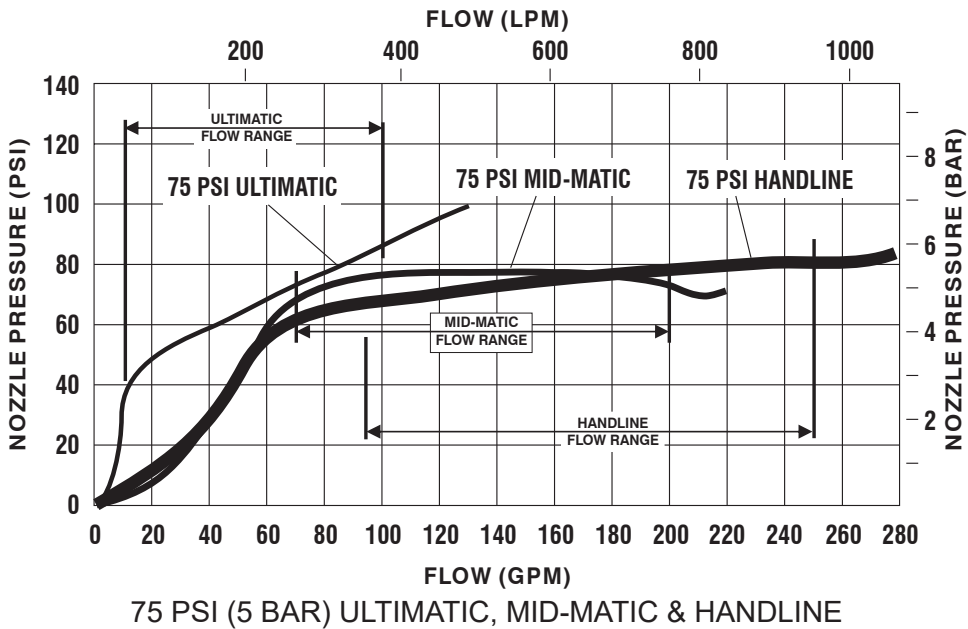

Figure 4.0 - Flow Characteristic Graphs

#### 4.1 NOZZLE FLOW CHARTS

The following charts give specific examples of maximum flow rates for particular situations. Friction losses may vary due to differences in hose construction resulting in flows different than those shown. For situations or lengths of hose not listed on the chart, approximate flows can be calculated using conventional hydraulics.

#### 4.1 NOZZLE FLOW CHARTS

100 PSI = 100 PSI ULTIMATIC

75 PSI = 75 PSI ULTIMATIC

### ULTIMATIC 125 Flow Chart

FLOW (GPM)	PUMP DISCHARGE PRESSURE (PSI)	3/4" HOSE						1" HOSE						1 1/2" HOSE					
		150 ft.		200 ft.		250 ft.		150 ft.		200 ft.		250 ft.		150 ft.		200 ft.		250 ft.	
		100 PSI	75 PSI	100 PSI	75 PSI	100 PSI	75 PSI	100 PSI	75 PSI	100 PSI	75 PSI	100 PSI	75 PSI	100 PSI	75 PSI	100 PSI	75 PSI	100 PSI	75 PSI
125	10	22	—	19	—	17	23	53	20	47	18	42	70	108	60	97	50	89	
150	16	25	13	21	11	19	34	61	29	54	26	49	100	125	85	114	75	106	
175	20	27	17	24	15	21	42	68	36	60	32	55	125	—	110	—	95	118	
200	23	30	20	26	18	23	50	75	42	66	38	60	—	—	125	—	110	—	
225	26	32	22	28	20	25	56	82	48	71	42	65	—	—	—	—	125	—	
250	29	34	25	30	22	27	62	88	52	77	46	69	—	—	—	—	—	—	
300	34	38	29	33	26	30	72	99	62	86	54	78	—	—	—	—	—	—	
350	38	42	33	37	29	33	80	109	70	95	62	85	—	—	—	—	—	—	
400	42	45	36	39	32	35	90	117	78	103	68	93	—	—	—	—	—	—	
450	46	49	39	42	34	38	98	—	84	110	74	99	—	—	—	—	—	—	
500	49	52	42	45	37	40	105	—	90	117	80	106	—	—	—	—	—	—	
600	55	57	48	50	42	44	120	—	100	—	90	117	—	—	—	—	—	—	

(1) Number in each box indicates flow (GPM). (2) Flows may vary with brand or condition of hose.  
 (3) Flows are approximate and do not reflect losses in preconnect piping.

7 BAR = 7 BAR ULTIMATIC

5 BAR = 5 BAR ULTIMATIC

### ULTIMATIC 125 Flow Chart

FLOW (LPM)	PUMP DISCHARGE PRESSURE (BAR)	19mm HOSE						25mm HOSE						38mm HOSE					
		45M		60M		75M		45M.		60M		75M		45M		60M		75M	
		7 BAR	5 BAR	7 BAR	5 BAR	7 BAR	5 BAR	7 BAR	5 BAR	7 BAR	5 BAR	7 BAR	5 BAR	7 BAR	5 BAR	7 BAR	5 BAR	7 BAR	5 BAR
8.6	40	85	----	70	----	65	85	200	75	180	70	160	265	410	225	365	190	335	
10	60	95	50	80	40	70	130	230	110	205	100	185	380	475	320	430	285	400	
12	75	100	65	90	55	80	160	255	135	225	120	210	475	----	415	----	360	445	
14	85	115	75	100	70	85	190	285	160	250	145	225	----	----	475	----	415	----	
15.5	100	120	85	105	75	95	210	310	180	270	160	245	----	----	----	----	475	----	
17	110	130	95	115	85	100	235	335	195	290	175	260	----	----	----	----	----	----	
21	130	145	110	125	100	115	275	375	235	325	205	295	----	----	----	----	----	----	
24	145	160	125	140	110	125	305	415	265	360	235	320	----	----	----	----	----	----	
28	160	170	135	150	120	130	340	445	295	390	255	350	----	----	----	----	----	----	
31	175	185	150	160	130	145	370	----	320	415	280	375	----	----	----	----	----	----	
34	185	195	160	170	140	150	395	----	340	445	305	400	----	----	----	----	----	----	
41	210	215	180	190	160	165	455	----	380	----	340	445	----	----	----	----	----	----	

(1) Number in each box indicates flow (LPM). (2) Flows may vary with brand or condition of hose.  
 (3) Flows are approximate and do not reflect losses in preconnect piping. (4) 1 BAR = 100 KPA

# MID-MATIC Flow & Nozzle Reaction Chart

100 PSI = 100 PSI MID-MATIC 75 PSI = 75 PSI MID-MATIC

FLOW (GPM)  
REACTION  
(LBS)

PUMP DISCHARGE PRESSURE (PSI)	1 1/2" HOSE						1 3/4" HOSE						2" HOSE					
	150 ft.		200 ft.		250 ft.		150 ft.		200 ft.		250 ft.		150 ft.		200 ft.		250 ft.	
	100 PSI	75 PSI	100 PSI	75 PSI	100 PSI	75 PSI	100 PSI	75 PSI	100 PSI	75 PSI	100 PSI	75 PSI	100 PSI	75 PSI	100 PSI	75 PSI	100 PSI	75 PSI
	Flow (GPM)	Reaction (LBS)	Flow (GPM)	Reaction (LBS)	Flow (GPM)	Reaction (LBS)	Flow (GPM)	Reaction (LBS)	Flow (GPM)	Reaction (LBS)	Flow (GPM)	Reaction (LBS)	Flow (GPM)	Reaction (LBS)	Flow (GPM)	Reaction (LBS)	Flow (GPM)	Reaction (LBS)
50	21 8	49 16	21 7	48 15	21 7	46 14	21 8	51 17	21 8	50 16	21 7	49 16	22 8	52 18	22 8	52 18	22 8	51 17
75	31 13	61 24	29 12	59 23	28 12	57 21	23 14	65 27	32 14	62 25	31 13	60 24	36 15	69 29	35 15	68 28	34 15	66 27
100	65 30	86 37	59 27	77 33	55 25	71 30	72 34	102 45	67 32	91 40	63 29	84 36	84 41	137 61	79 38	120 53	75 36	108 48
125	93 45	115 51	84 40	101 44	77 37	92 40	108 54	142 63	97 48	124 55	91 44	111 49	135 69	216 91	122 62	175 77	113 57	155 69
150	117 59	141 63	105 52	123 55	96 47	110 49	141 72	178 79	125 63	153 68	114 57	137 61	196 101	---	168 87	221 95	151 78	195 85
175	140 72	165 73	124 63	142 63	112 57	128 57	174 90	214 90	151 78	179 79	136 70	159 70	---	---	212 109	---	187 97	224 98
200	162 84	187 81	141 73	160 71	128 65	143 64	204 105	---	175 91	204 87	157 81	179 79	---	---	---	---	222 113	---
225	183 94	208 88	158 82	176 78	142 73	157 70	---	---	198 102	222 95	176 91	198 86	---	---	---	---	---	---
250	202 104	221 96	174 90	198 79	155 80	179 69	---	---	218 112	---	194 100	215 91	---	---	---	---	---	---

(1) Number on top in each box indicates flow (GPM), and number on bottom indicates nozzle reaction (LBS).  
 (2) Flows may vary with brand or condition of hose. (3) Flows are approximate and do not reflect losses in preconnect piping.

# MID-MATIC Flow & Nozzle Reaction Chart

7 BAR = 7 BAR MID-MATIC 5 BAR = 5 BAR MID-MATIC

FLOW (LPM)  
REACTION  
(KG)

PUMP DISCHARGE PRESSURE (BAR)	38mm HOSE						45mm HOSE						50mm HOSE					
	45M		60M		75M		45M		60M		75M		45M		60M		75M	
	7 BAR	5 BAR	7 BAR	5 BAR	7 BAR	5 BAR	7 BAR	5 BAR	7 BAR	5 BAR	7 BAR	5 BAR	7 BAR	5 BAR	7 BAR	5 BAR	7 BAR	5 BAR
	Flow (LPM)	Reaction (KG)	Flow (LPM)	Reaction (KG)	Flow (LPM)	Reaction (KG)	Flow (LPM)	Reaction (KG)	Flow (LPM)	Reaction (KG)	Flow (LPM)	Reaction (KG)	Flow (LPM)	Reaction (KG)	Flow (LPM)	Reaction (KG)	Flow (LPM)	Reaction (KG)
3.5	80 4	210 8	80 3	190 7	80 3	175 6	80 4	245 10	80 4	225 9	80 3	205 8	85 4	310 12	85 4	285 11	85 4	255 10
5.2	115 6	350 14	110 5	315 12	105 5	285 11	85 6	420 17	120 6	380 15	115 6	345 14	135 7	535 23	130 7	485 20	130 7	450 19
7	245 14	460 19	225 12	405 16	210 11	365 15	275 15	540 24	255 15	490 20	240 13	445 18	320 19	695 33	300 17	630 29	285 16	580 25
8.6	350 20	540 24	320 18	475 20	290 17	430 18	410 25	650 30	365 22	575 25	345 20	520 23	510 31	805 41	460 28	750 36	430 26	690 32
10	445 27	615 28	395 24	540 24	365 21	490 21	535 33	740 35	475 29	660 30	430 26	600 26	740 46	---	635 40	---	570 35	775 38
12	530 33	680 31	470 29	600 27	425 26	540 24	660 41	805 41	570 35	725 35	515 32	660 30	---	---	800 50	---	710 44	845 45
14	615 38	740 35	535 33	655 30	485 30	590 26	770 48	---	660 41	785 39	595 37	715 34	---	---	---	---	840 51	---
15.5	695 43	790 40	600 37	705 33	535 33	635 29	---	---	750 46	835 44	665 41	770 38	---	---	---	---	---	---
17	765 47	835 44	660 41	750 36	585 36	680 31	---	---	825 51	---	735 45	815 41	---	---	---	---	---	---

(1) Number on top in each box indicates flow (LPM), and number on bottom indicates nozzle reaction (KG).  
 (2) Flows may vary with brand or condition of hose. (3) Flows are approximate and do not reflect losses in preconnect piping.



# HANDLINE Flow & Nozzle Reaction Chart

Note: For Nozzles with Serial # TFT-H465101 and/or Manufactured after 12/01/2003

100 PSI = 100 PSI HANDLINE    75 PSI = 75 PSI HANDLINE

PUMP DISCHARGE PRESSURE (PSI)	1 1/2" HOSE						1 3/4" HOSE						2" HOSE						2-1/2" HOSE					
	150 ft.		200 ft.		250 ft.		150 ft.		200 ft.		250 ft.		150 ft.		200 ft.		250 ft.		150 ft.		200 ft.		250 ft.	
	100 PSI	75 PSI	100 PSI	75 PSI	100 PSI	75 PSI	100 PSI	75 PSI	100 PSI	75 PSI	100 PSI	75 PSI	100 PSI	75 PSI	100 PSI	75 PSI	100 PSI	75 PSI	100 PSI	75 PSI	100 PSI	75 PSI	100 PSI	75 PSI
50	47 16	49 17	46 15	47 15	45 14	45 15	50 18	51 18	49 17	50 17	47 16	48 16	52 19	53 20	51 18	51 18	50 18	51 18	53 20	54 20	52 19	53 20	52 19	53 20
75	59 25	64 26	58 23	60 24	56 30	57 23	60 26	72 31	59 25	66 27	58 25	63 25	63 27	90 39	62 26	80 34	61 25	75 32	65 30	122 55	65 29	115 51	65 30	110 44
100	85 42	96 41	69 31	84 35	65 30	75 32	82 40	115 50	76 36	102 45	72 35	92 40	100 50	148 66	91 45	127 58	85 41	120 53	135 70	255 121	127 65	222 105	122 63	205 108
125	100 50	123 55	90 45	109 44	82 40	98 43	120 61	147 67	107 55	130 57	97 108	118 54	142 74	198 93	137 71	175 80	126 65	157 72	245 134	300 155	223 120	290 146	205 110	280 135
150	126 55	145 65	111 55	127 56	101 49	116 51	150 78	177 82	128 65	156 68	122 63	141 64	197 106	240 114	175 93	210 98	149 79	190 88	323 182	327 187	312 175	317 177	281 155	307 165
175	142 75	166 76	130 66	145 65	117 60	130 58	178 95	204 95	156 83	174 78	142 75	160 73	239 130	278 134	210 113	242 115	190 101	217 102	351 217	352 220	340 204	340 203	330 190	330 191
200	165 87	185 85	146 75	160 73	134 67	145 65	203 109	222 105	177 94	198 94	160 84	180 74	275 151	296 152	243 123	271 130	218 118	244 115	375 252	376 247	362 231	364 252	352 217	352 219
225	185 98	201 94	161 85	176 81	146 86	157 72	227 124	250 119	197 106	216 101	177 94	194 90	310 172	314 174	270 148	290 146	242 132	267 127	---	---	---	---	373 245	375 247
250	201 106	217 102	174 92	189 87	157 83	170 79	247 135	269 123	216 116	233 110	194 103	209 98	320 180	330 190	295 164	305 163	265 145	285 140	---	---	---	---	394 270	395 275

- (1) Number on top in each box indicates flow (GPM), and number on bottom indicates nozzle reaction (LBS).  
 (2) Flows may vary with brand or condition of hose. (3) Flows are approximate and do not reflect losses in preconnect piping.

# HANDLINE Flow & Nozzle Reaction Chart

Note: For Nozzles with Serial # TFT-H465101 and/or Manufactured after 12/01/2003

7 BAR = 7 BAR HANDLINE    5 BAR = 5 BAR HANDLINE

PUMP DISCHARGE PRESSURE (BAR)	38mm HOSE						45mm HOSE						50mm HOSE						65mm HOSE					
	45M		60M		75M		45M		60M		75M		45M		60M		75M		45M		60M		75M	
	7 BAR	5 BAR	7 BAR	5 BAR	7 BAR	5 BAR	7 BAR	5 BAR	7 BAR	5 BAR	7 BAR	5 BAR	7 BAR	5 BAR	7 BAR	5 BAR	7 BAR	5 BAR	7 BAR	5 BAR	7 BAR	5 BAR	7 BAR	5 BAR
3.5	178 7	185 8	174 7	178 7	170 6	170 7	189 8	193 8	185 8	189 8	178 7	182 7	197 9	201 9	193 8	193 8	189 8	193 8	201 9	204 9	197 9	201 9	197 9	201 9
5.2	223 11	242 12	220 10	227 11	212 13	216 10	227 12	273 14	223 11	250 12	220 11	238 11	238 12	341 18	235 12	303 15	231 11	284 15	246 14	462 25	246 14	435 21	246 14	416 20
7	322 19	363 19	261 14	318 16	246 14	284 15	310 18	435 23	288 16	386 16	273 18	348 18	379 20	560 30	344 20	481 26	322 19	454 24	511 32	968 55	481 29	840 28	462 29	776 49
8.6	379 23	466 25	341 20	413 20	310 18	371 20	454 28	556 30	405 25	492 26	367 26	447 25	538 34	750 42	519 32	662 36	477 29	594 33	927 61	1136 70	844 54	1098 66	776 50	1060 61
10	477 29	549 29	420 25	481 25	382 22	439 23	568 35	670 37	625 29	591 31	462 29	534 29	746 48	908 52	662 42	795 44	564 36	719 40	1223 83	1238 85	1181 79	1200 80	1064 70	1162 75
12	538 34	628 34	492 30	549 29	443 27	492 26	674 43	772 43	591 37	659 35	538 34	606 33	905 59	1052 61	795 51	916 52	719 46	821 46	1329 98	1332 100	1287 93	1287 92	1249 86	1249 87
14	625 40	700 38	553 34	606 33	507 30	549 29	768 49	840 48	670 37	700 43	606 38	681 38	1041 68	1120 69	920 56	1026 59	825 54	924 52	1420 114	1423 112	1370 105	1378 114	1332 98	1332 99
15.5	700 44	761 43	609 39	666 37	553 39	594 33	859 56	946 54	746 48	818 46	670 42	734 41	1173 78	1189 79	1022 67	1098 66	916 60	1011 58	---	---	---	---	1412 111	1420 112
17	761 48	821 46	659 42	715 39	594 38	644 36	935 61	1018 56	818 53	882 50	734 47	791 44	1211 82	1249 86	1117 74	1155 74	1003 66	1079 64	---	---	---	---	1491 122	1495 125

- (1) Number on top in each box indicates flow (LPM), and number on bottom indicates nozzle reaction (KG).  
 (2) Flows may vary with brand or condition of hose. (3) Flows are approximate and do not reflect losses in preconnect piping.

The previous charts are specific examples of maximum flow rates for particular situations. Friction losses may vary due to differences in hose construction resulting in flows different than those shown. For situations or lengths of hose not listed on the chart, approximate flows can be calculated using conventional hydraulics.

## 4.2 REACH AND TRAJECTORY

Care must be taken to avoid dents or nicks in the nozzle tip because they can seriously affect the stream reach. All reach testing was taken in still air conditions at an elevation of 30 degrees.

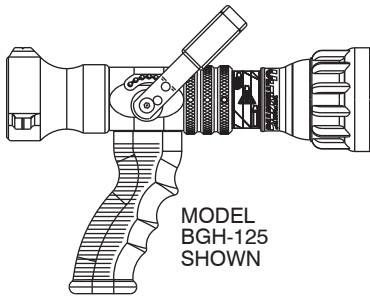

### ULTIMATIC 100 PSI (7BAR) VERSION

Automatic Pressure Control Flow Range:  
10-125 gpm @ 100 psi  
40-500 l/min @ 7 bar

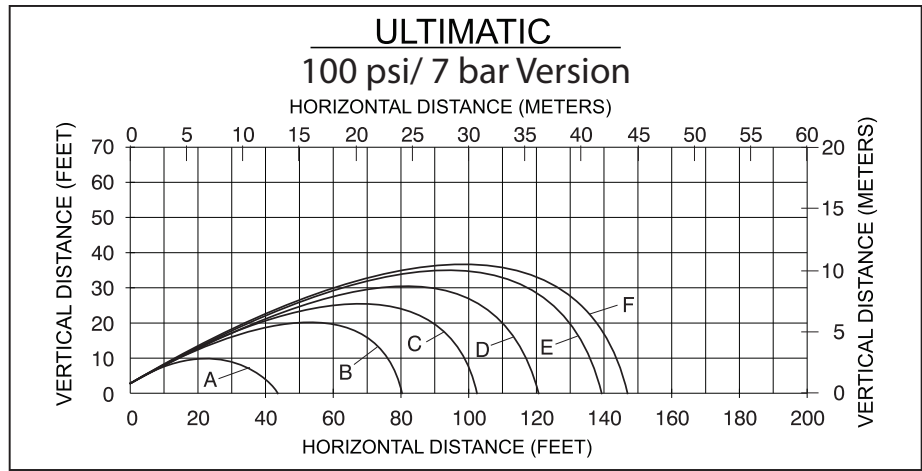

Ultimatic 100 psi (7 bar) Version													
Curve	A	B	C	D	E	F		A	B	C	D	E	F
Flow (gpm)	10	25	50	75	100	125	(l/min)	38	95	189	284	379	473
Pressure (psi)	28	69	84	91	110	122	(bar)	1.9	4.8	5.8	6.3	7.6	8.4
Reaction (lbs)	3	10	23	36	53	70	(kgf)	1	5	10	16	24	32

### ULTIMATIC 75 PSI (5 BAR) VERSION

Automatic Pressure Control Flow Range:  
10-100 gpm @ 75 psi  
40-400 l/min @ 5 bar

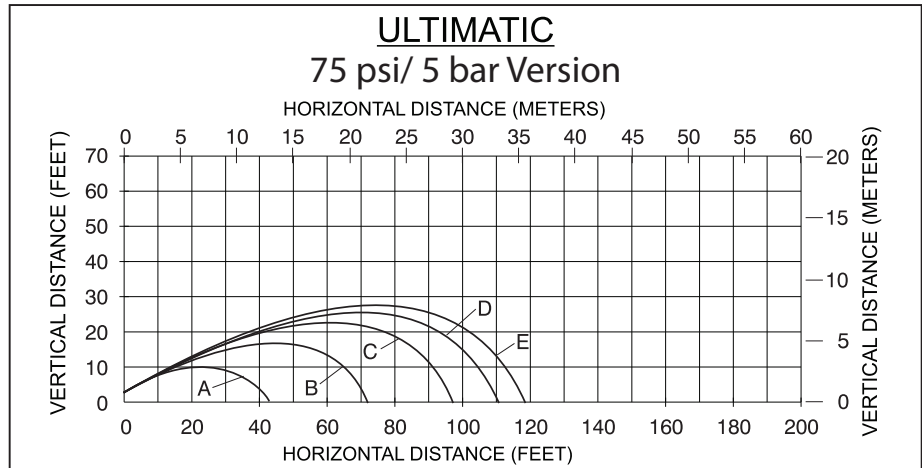

Ultimatic 75 psi (5 bar) Version											
Curve	A	B	C	D	E		A	B	C	D	E
Flow (gpm)	10	25	50	75	100	(l/min)	38	95	189	284	379
Pressure (psi)	26	46	59	69	80	(bar)	1.8	3.2	4.1	4.8	5.5
Reaction (lbs)	3	9	19	31	45	(kgf)	1	4	9	14	20

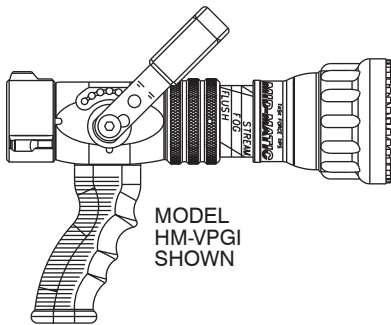

MODEL  
HM-VPGI  
SHOWN

**MID-MATIC 100 PSI (7 BAR) VERSION**  
Automatic Pressure Control Flow Range:  
70-200 gpm @ 100 psi  
260-760 l/min @ 7 bar

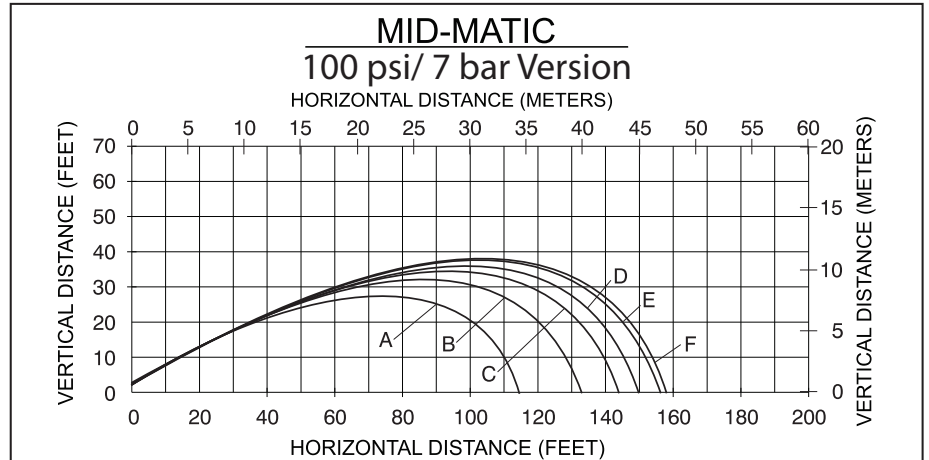

Mid-Matic 100 psi (7 bar) Version													
Curve	A	B	C	D	E	F		A	B	C	D	E	F
Flow (gpm)	70	95	125	150	175	200	(l/min)	265	360	473	568	662	757
Pressure (psi)	83	89	93	95	98	96	(bar)	5.7	6.1	6.4	6.6	6.8	6.6
Reaction (lbs)	32	45	61	74	87	99	(kgf)	15	20	28	34	39	45

**MID-MATIC 75 PSI ( 5 BAR) VERSION**  
Automatic Pressure Control Flow Range:  
70-200 gpm @ 75 psi  
260-760 l/min @ 5 bar

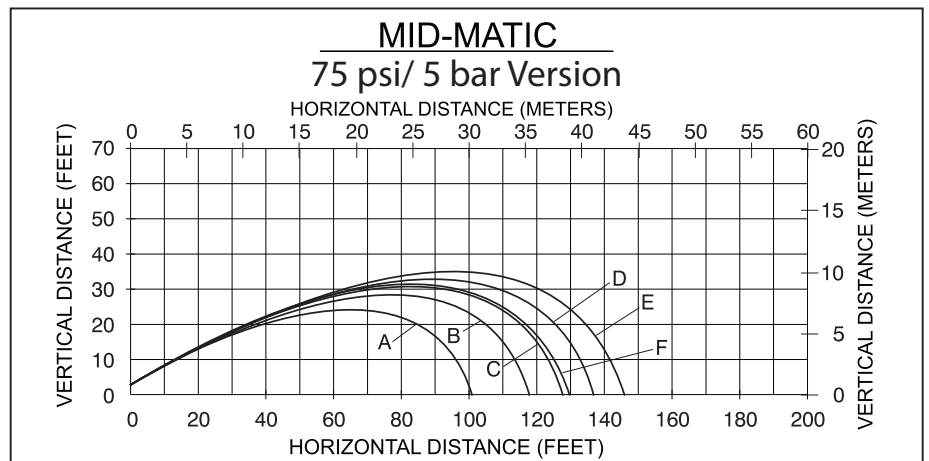

Mid-Matic 75 psi (5 bar) Version													
Curve	A	B	C	D	E	F		A	B	C	D	E	F
Flow (gpm)	70	95	125	150	175	200	(l/min)	265	360	473	568	662	757
Pressure (psi)	68	74	75	78	77	82	(bar)	4.7	5.1	5.2	5.4	5.3	5.7
Reaction (lbs)	29	41	55	67	78	91	(kgf)	13	19	25	30	35	41

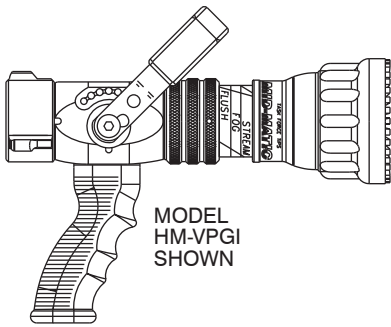

**MID-MATIC 55 PSI (3 BAR) VERSION**  
Automatic Pressure Control Flow Range:  
70-180 gpm @ 55 psi  
260-680 l/min @ 3 bar

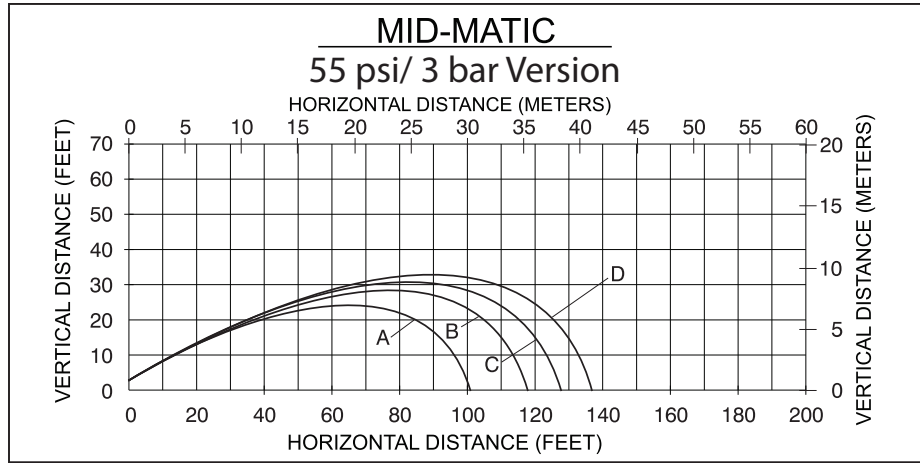

Mid-Matic 55 psi (3 bar) Version									
Curve	A	B	C	D		A	B	C	D
Flow (gpm)	70	125	150	180	(l/min)	265	473	568	681
Pressure (psi)	38	47	52	64	(bar)	2.6	3.2	3.6	4.4
Reaction (lbs)	22	43	55	73	(kgf)	10	20	25	33

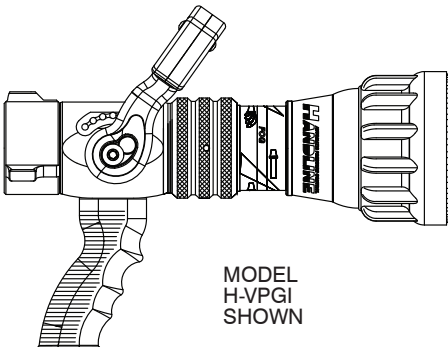

**HANDLINE 100 PSI (7 BAR) VERSION**  
Automatic Pressure Control Flow Range:  
95-300 gpm @ 100 psi  
360-1150 l/min @ 7 bar

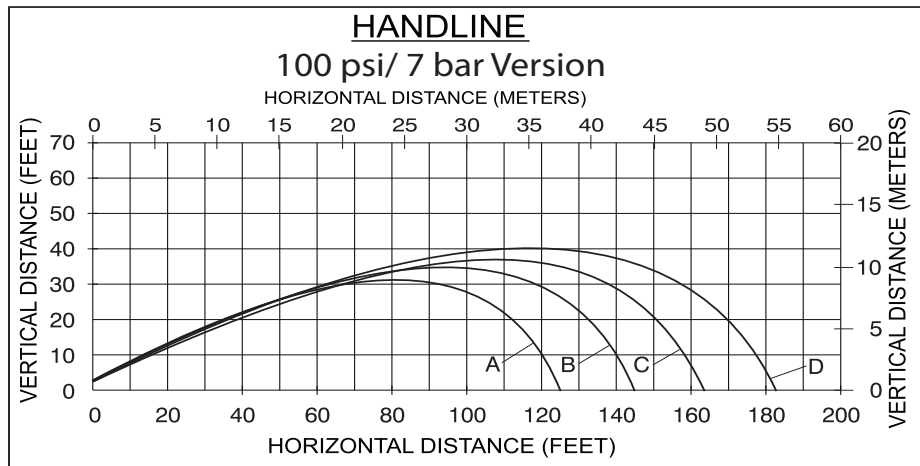

Handline, 100 psi (7 bar) Version									
Curve	A	B	C	D		A	B	C	D
Flow (gpm)	95	125	200	300	(l/min)	360	473	757	1136
Pressure (psi)	91	100	100	126	(bar)	6.3	6.9	6.9	8.7
Reaction (lbs)	46	63	101	170	(kgf)	21	29	46	77

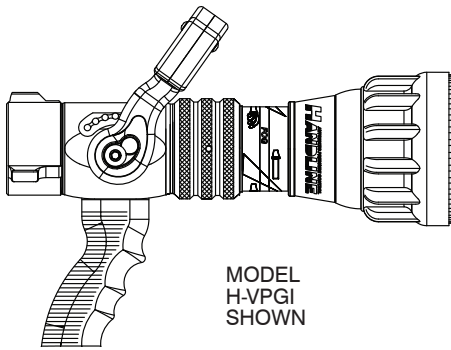

**HANDLINE 75 PSI (5 BAR) VERSION**

Automatic Pressure Control Flow Range:  
 95-250 gpm @ 75 psi  
 360-950 l/min @ 5 bar

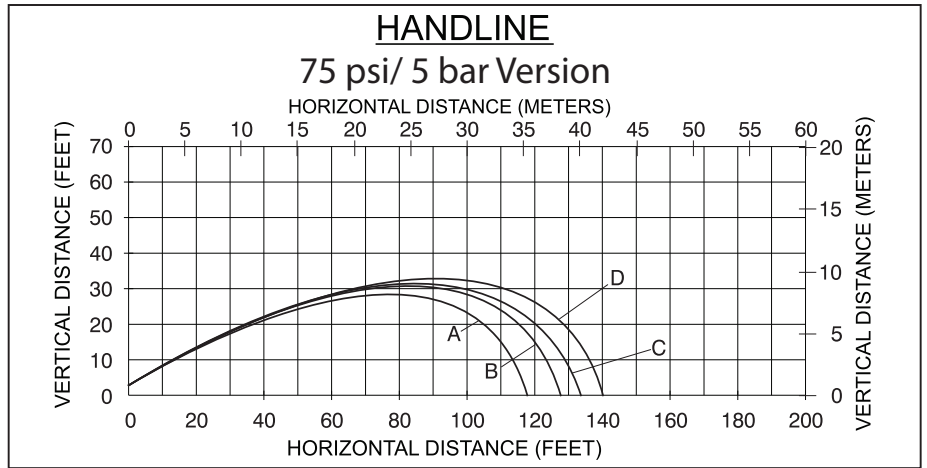

Handline, 75 psi (5 bar) Version									
Curve	A	B	C	D		A	B	C	D
Flow (gpm)	95	125	200	250	(l/min)	360	473	757	946
Pressure (psi)	68	72	78	81	(bar)	4.7	5.0	5.4	5.6
Reaction (lbs)	40	54	89	113	(kgf)	18	25	40	51

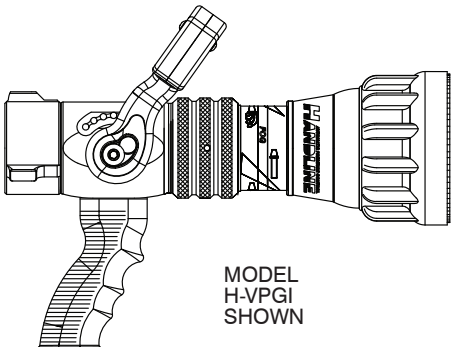

**HANDLINE 55 PSI (3 BAR) VERSION**

Automatic Pressure Control Flow Range:  
 95-225 gpm @ 55 psi  
 360-850 l/min @ 3 bar

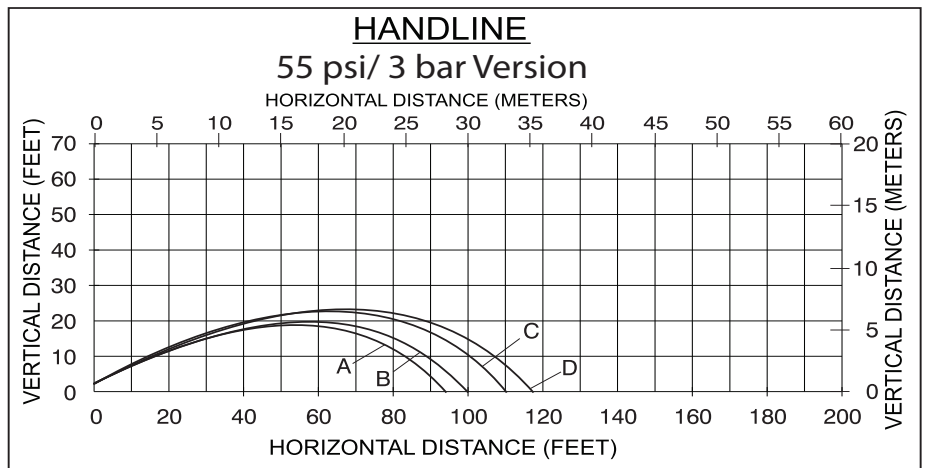

Handline, 55 psi (3 bar) Version									
Curve	A	B	C	D		A	B	C	D
Flow (gpm)	95	125	175	225	(l/min)	360	473	662	852
Pressure (psi)	48	52	60	71	(bar)	3.3	3.6	4.1	4.9
Reaction (lbs)	33	46	68	96	(kgf)	15	21	31	44

### 4.3 ULTIMATIC INITIAL OPENING ADJUSTMENT OPTION

Initial opening is the small gap between the back of the baffle and the front of the nozzle's discharge opening (barrel cone). This small gap provides a small amount of flow until line pressure/flow reaches a point to starting moving the automatic control unit and the baffle forward allowing the rated flow range of the nozzle.

If no initial opening is desired the initial opening can be adjusted back to zero. Looking inside the inlet end of the nozzle there is a small plastic screw. A long 7/32" hex wrench can be insert into the inlet end of the nozzle through the center of the debris screen then down into the hex of the plastic screw. Turn the screw 1/4 turn counterclockwise (unthreading it slightly from the valve plug) to set the initial opening to approximately a zero gap size.

**WARNING** Once this adjustment is made the nozzle will flow little to no water at low pump pressures when the valve handle is in the open position.

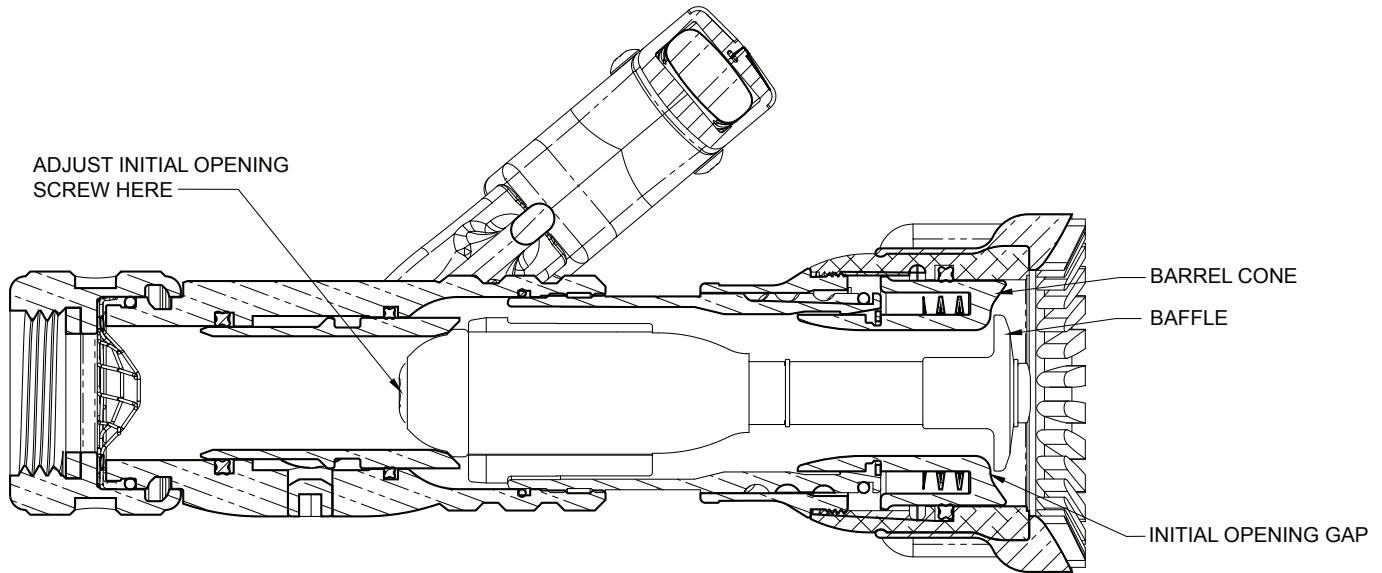

Figure 4.3  
ULTIMATIC Cut-A-Way

## 5.0 NOZZLE CONTROLS

Nozzle control valves must be opened slowly to eliminate unnecessary strain on the hose and couplings and reduce pressure surges.

### 5.1 FLOW CONTROL

#### 5.1.1 LEVER TYPE FLOW CONTROL

On models that use a lever type valve handle, the nozzle is shut off when the handle is fully forward. The valve handle has detented flow positions. These detent positions allow the nozzle operator to regulate the flow of the nozzle depending on the need or what can be safely and effectively handled. TFT recommends the use of a pistol grip for easier handling. For additional stress reduction, a hose rope or strap may also be used. This permits more effective use and ease of advancement, while minimizing strain and fatigue.

Nozzles attached to an in-service hose shall be stored in the off position

#### 5.1.2 TIP ONLY

Tip only nozzles have NO shut-off valve within the nozzle and MUST be used with a separate ball valve attached to the nozzle. Using a nozzle without a shutoff is an unsafe practice and should never be done.

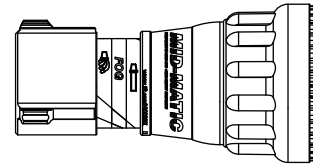

#### 5.1.3 BALL SHUTOFF

A separate ball valve for use with Tip Only nozzles is shut off when the valve handle is fully forward. Pulling back on the handle opens the valve. Open valve slowly to avoid sudden changes in nozzle reaction. Close valve slowly to prevent water hammer. Note: In partially open positions a ball valve will cause turbulence and adversely affect stream quality. Nozzles attached to an in-service hose shall be stored in the off position.

#### 5.1.4 TWIST SHUTOFF

On models that use a twist flow control, the valve is opened or closed by rotating the valve ring. Rotating the ring clockwise (as seen from the operating position behind the nozzle) closes the valve, while counterclockwise rotation opens it. Detents are provided at four intermediate positions and the position of the valve is shown by the exposed valve position label. Nozzles attached to an in-service hose shall be stored in the off position.

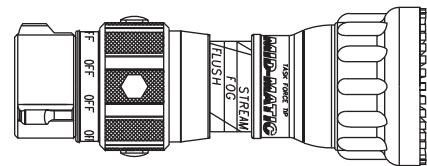

#### 5.1.5 IMPULSE TRIGGER FLOW CONTROL

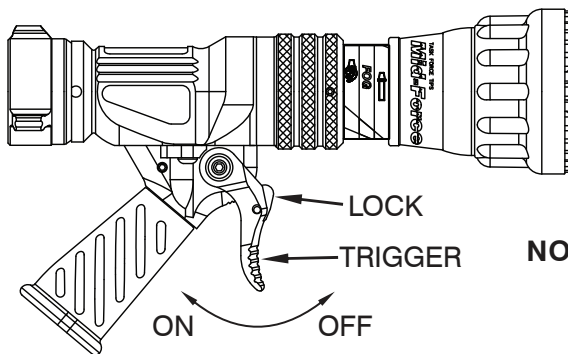

**NOTE: THE TRIGGER RETURNS TO OFF IF NOT HELD OR LOCKED**



**Do not intentionally release the nozzle while flowing and trust the valve to shut off automatically. The trigger nozzle's ability to shut off by itself represents an extra level of safety when following normal nozzle handling procedures. To rely on it as the sole means of safety increases the risk of injury from an out of control nozzle. Release nozzle when flow has stopped.**

### 5.1.5.1 IMPULSE TRIGGER LOCK

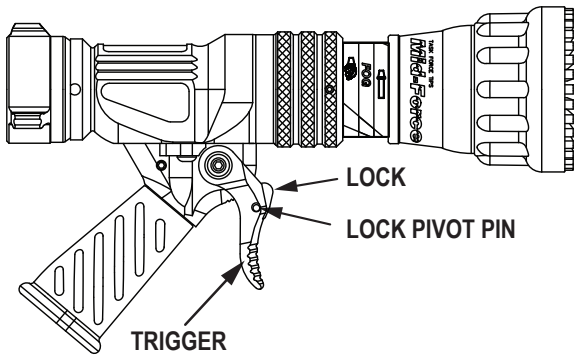

**To Lock:** Push on the lock while pulling back the trigger to engage one of the four locked positions.

**To Release:** Pull back slightly on trigger without any pressure on the lock. The spring loaded lock should automatically move to the unlocked position.

Use an 1/8" (3mm) punch to push out pin and remove lock if the lock is not desired.

**WARNING** When the trigger lock is engaged, the nozzle will not shut off if dropped. Always shut off nozzle before releasing the pistol grip to avoid injury from an out of control nozzle.

### 5.1.5.2 TRIGGER FLOW CONTROL SPEED ADJUSTMENT

The IMPULSE valve contains a slow close mechanism to prevent the nozzle from slamming off if the trigger is suddenly released. The closing speed is set at the factory to be slow enough to reduce water hammer, ("water hammer" is always present in any valve when it is shut off. The slow close mechanism will reduce this but cannot eliminate it completely) but fast enough to reduce the potential danger of hose whipping from a dropped nozzle. The closing speed may be adjusted as shown in the figure.5.1.5.2.

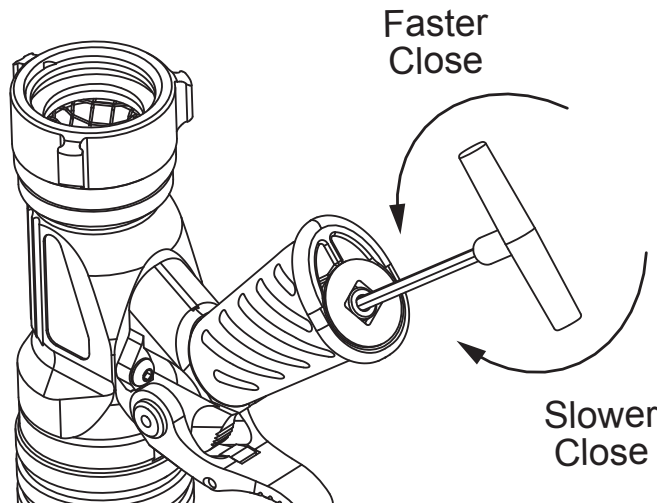

Do not unscrew the adjuster past the end of the hand grip (to unscrew it too far could result in the loss of dampening fluid.)

**WARNING** As the closing time is increased so does the risk of injury from an out of control nozzle. A flowing nozzle can cause injury within the first second of lost control. Use caution when adjusting the closing speed and always verify performance after adjustment.



### 5.1.5.3 NORMAL OPERATING POSITION

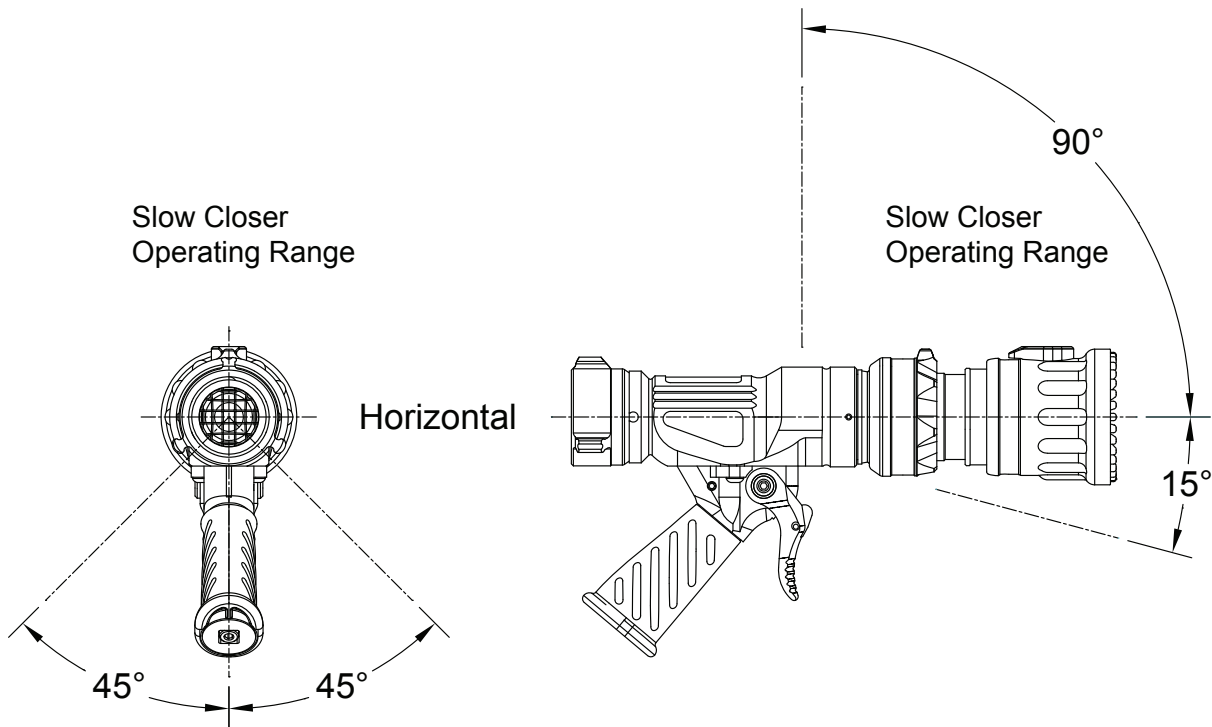

**WARNING** The Slow Close Feature relies on a fluid and air combination in the pistol grip. For proper function, the pistol grip should be within its normal operating position. The normal operating position is with the nozzle horizontal or pointing up with the pistol grip within 45 degrees of vertical. Releasing the trigger suddenly outside of the normal orientation will likely result in faster shut-off causing a higher pressure spike and increasing the risk of a burst hose. Do not suddenly release the trigger when operating outside of the nozzle's normal orientation.

## 5.2 PATTERN AND FLUSH CONTROL

### 5.2.1 PATTERN CONTROL

TFT's nozzles have full pattern control from straight stream to wide fog. Turning the stream shaper clockwise (as seen from the operating position behind the nozzle) moves the shaper to the straight stream position. Turning the shaper counterclockwise will result in an increasingly wider pattern.

Since the stream trim point varies with flow, the stream should be "trimmed" after changing the flow to obtain the straightest and farthest reaching stream. To properly trim the stream, first open the pattern to narrow fog. Then close the stream to parallel to give maximum reach. NOTE: Turning the shaper further forward will cause stream crossover and reduce the effective reach of the nozzle. The nozzle reaction is greatest when the shaper is in the straight stream position. The nozzle operator must be prepared for a change in reaction as the pattern is changed.

### 5.2.2 FLUSH CONTROL

Small debris passes through the debris screen (if equipped) and may get caught inside the nozzle. This trapped material will cause poor stream quality, shortened reach, and reduced flow. To remove small debris, the nozzle may be flushed as follows:

- While still flowing water, rotate the shaper counterclockwise (as viewed from behind the nozzle) to the flush position. (increased resistance will be felt on the SHAPER or RING as the nozzle goes into flush) This will open the nozzle allowing debris to pass through.
- During flush the nozzle reaction will decrease as the pattern becomes wider and the pressure drops. The nozzle operator must be prepared for an increase of nozzle reaction when returning the nozzle from the flush position to retain control of the nozzle.
- Rotate the selector ring out of flush to continue normal operations.

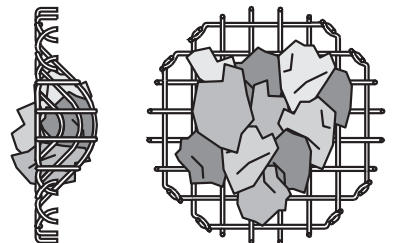

FIGURE 3 - Debris Screen

**WARNING** Large amounts or pieces of debris may be unflushable and can reduce the flow of the nozzle resulting in an ineffective flow. In the event of a blockage, it may be necessary to retreat to a safe area, uncouple the nozzle and remove debris.

## 6.0 USE WITH FOAM

The nozzle may be used with foam solutions. Refer to fire service training for the proper use of foam.

### WARNING

For Class B fires, lack of foam or interruption in the foam stream can cause a break in the foam blanket and greatly increase the risk of injury or death. Assure that:

- Application rate is sufficient (see NFPA 11 or foam manufacturer's recommendations)
- Enough concentrate is on hand to complete task (see NFPA for minimum duration time requirements)
- Foam logistics have been carefully planned.

Allow for such things as:

- Storage of foam in a location not exposed to the hazard it protects
- Personnel, equipment and technique to deliver foam at a rapid enough rate
- Removal of empty foam containers
- Clear path to deliver foam, as hoses and other equipment and vehicles are deployed

### WARNING

Improper use of foam can result in injury or damage to the environment. Follow foam manufacturer's instructions and fire service training to avoid:

- Using wrong type of foam on a fire. i.e. Class A foam on a Class B fire.
- Plunging foam into pools of burning liquid fires.
- Causing environmental damage.
- Directing stream at personnel.

### WARNING

There are a wide variety of foam concentrates. Each user is responsible for verifying that any foam concentrate chosen to be used with this unit has been tested to assure that the foam obtained is suitable for the purpose intended.

### WARNING

Use of compressed air foam (CAF) with hand held nozzles can cause sudden surges in nozzle reaction force resulting in risk of injury or death from loss of footing or hose whipping. Be prepared for sudden changes in nozzle reaction caused by:

- Slug loading (Loss of foam concentrate sends slugs of air and water into the nozzle)
- Sudden release of built-up pressure in the hose when opening a nozzle

## 6.1 FOAM ASPIRATING ATTACHMENTS

Multi-expansion or low expansion aspirating attachments may be used with nozzles to increase the expansion ratio. These foam tubes attach and detach quickly from the nozzle. As expansion ratio is increased, the reach of the nozzle will be decreased due to the greater amount of bubbles in the stream and their ability to penetrate the air. Generally the straight stream reach with foam is approximately 10% less than with water only. Actual results will vary based on brand of foam, hardness of water, temperature, etc. For specific information, see LIA-025 (MANUAL: Foam Attachments for TFT Nozzles).

## 7.0 USE OF NOZZLES

IT IS THE RESPONSIBILITY OF THE INDIVIDUAL FIRE DEPARTMENT OR AGENCY TO DETERMINE PHYSICAL CAPABILITIES AND SUITABILITY FOR AN INDIVIDUAL'S USE OF THIS EQUIPMENT.

Many factors contribute to the extinguishment of a fire. Among the most important is delivering water at a flow rate sufficient to absorb heat faster than it is being generated. The flow rate depends largely on the pump discharge pressure and hose friction loss. It can be calculated using a hydraulic equation such as:

$$PDP = NP + FL + DL + EL$$

PDP = Pump discharge pressure in PSI

NP = Nozzle pressure in PSI

FL = Hose friction loss in PSI

DL = Device loss in PSI

EL = Elevation loss in PSI

This manual is not intended to act as a training guide for safe fireground tactics and operations. For additional information visit [www.ift.com](http://www.ift.com) or contact customer service at 800-348-2686.

## 8.0 APPROVALS

Many nozzle configurations carry the FM Approval rating, NFPA certification, or EN certification.

## 9.0 COLOR CODED VALVE HANDLE AND PISTOL GRIP

TFT nozzles with lever type valve handles are supplied with black valve handle covers and pistol grips. The handle covers and pistol grips are available from TFT in various colors for those departments wishing to color code the nozzle to the discharge controls. A colored handle cover set will be sent upon receipt of the warranty card by TFT. Your department's name can also be engraved on the covers (see warranty card for more information).

Handle covers are replaceable by removing the four screws that hold the handle covers in place. Use a 3/32" allen wrench when replacing screws. Pistol grip is replaceable by following TFT instruction sheet LTT-108.

For standardization NFPA 1901 (A-4-9.3) recommends the following color code scheme:

Preconnect #1 or Bumper Jump Line  
 Preconnect or discharge #2  
 Preconnect or discharge #3  
 Preconnect or discharge #4  
 Preconnect or discharge #5  
 Preconnect or discharge #6  
 Preconnect or discharge #7  
 Foam Lines

Orange  
 Red  
 Yellow  
 White  
 Blue  
 Black  
 Green  
 Red w/ White border (Red/White)

Other Colors Available:

- Gray
- Pink
- Purple
- Tan

## 9.1 IMPULSE TRIGGER VALVE SYSTEM NOZZLE COLORED PISTOL GRIPS

The TFT Impulse Trigger Valve System nozzles are supplied with black pistol grip covers. The pistol grip covers are available from TFT in various colors for those departments wishing to color code the nozzle to the discharge controls. Follow the steps below to change the pistol grip cover.

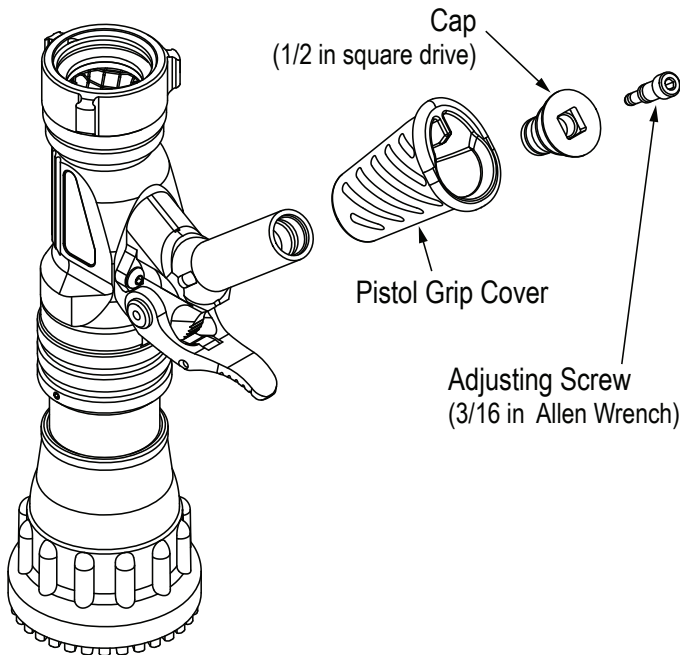

- 1) Orient nozzle vertically. This keeps the dampening fluid in the pistol grip from spilling out.
- 2) Remove the Cap. (1/2 in square drive) The Adjusting Screw (3/16 in Allen Wrench) may need to be turned in or removed to be able to engage the square pocket in the cap. Note the position of the Adjusting Screw before moving it.
- 3) Slide off the Pistol Grip Cover and install a new one. Be sure the Pistol Grip Cover's internal rib is toward the back of the nozzle.
- 4) Reinstall the Cap until it bottoms out on its shoulder.
- 5) Reinstall or reposition the Adjusting Screw if it has been moved from its original location.
- 6) Flow nozzle to check performance of slow closer. Adjust as needed (see section 5.1.5.2).

## 10.0 WARRANTY

Task Force Tips, Inc., 3701 Innovation Way, Valparaiso, Indiana 46383-9327 USA ("TFT") warrants to the original purchaser of its nozzles ("equipment"), and to anyone to whom it is transferred, that the equipment shall be free from defects in material and workmanship during the five (5) year period from the date of purchase.

TFT's obligation under this warranty is specifically limited to replacing or repairing the equipment (or its parts) which are shown by TFT's examination to be in a defective condition attributable to TFT. To qualify for this limited warranty, the claimant must return the equipment to TFT, at 3701 Innovation Way, Valparaiso, Indiana 46383-9327 USA, within a reasonable time after discovery of the defect. TFT will examine the equipment. If TFT determines that there is a defect attributable to it, TFT will correct the problem within a reasonable time. If the equipment is covered by this limited warranty, TFT will assume the expenses of repair.

If any defect attributable to TFT under this limited warranty cannot be reasonably cured by repair or replacement, TFT may elect to refund the purchase price of the equipment, less reasonable depreciation, in complete discharge of its obligations under this limited warranty. If TFT makes this election, claimant shall return the equipment to TFT free and clear of any liens and encumbrances.

This is a limited warranty. The original purchaser of the equipment, any person to whom it is transferred, and any person who is an intended or unintended beneficiary of the equipment, shall not be entitled to recover from TFT any consequential or incidental damages for injury to person and/or property resulting from any defective equipment manufactured or assembled by TFT. It is agreed and understood that the price stated for the equipment is in part consideration for limiting TFT's liability. Some states do not allow the exclusion or limitation of incidental or consequential damages, so the above may not apply to you.

TFT shall have no obligation under this limited warranty if the equipment is, or has been, misused or neglected (including failure to provide reasonable maintenance) or if there have been accidents to the equipment or if it has been repaired or altered by someone else.

THIS IS A LIMITED EXPRESS WARRANTY ONLY. TFT EXPRESSLY DISCLAIMS WITH RESPECT TO THE EQUIPMENT ALL IMPLIED WARRANTIES OF MERCHANTABILITY AND ALL IMPLIED WARRANTIES OF FITNESS FOR A PARTICULAR PURPOSE. THERE IS NO WARRANTY OF ANY NATURE MADE BY TFT BEYOND THAT STATED IN THIS DOCUMENT.

This limited warranty gives you specific legal rights, and you may also have other rights which vary from state to state.

## 11.0 MAINTENANCE

TFT nozzles are designed and manufactured to be damage resistant and require minimal maintenance. However, as the primary firefighting tool upon which your life depends, it should be treated accordingly. To help prevent mechanical damage, do not drop or throw equipment.

### 11.1 FIELD LUBRICATION

All Task Force Tips' nozzles are factory lubricated with high quality silicone grease. This lubricant has excellent wash out resistance and long term performance in firefighting nozzles. If your department has unusually hard or sandy water, the moving parts of the nozzle may be affected. Foam agents and water additives contain soaps and chemicals that may break down the factory lubrication. The moving parts of the nozzle should be checked on a regular basis for smooth and free operation, and for signs of damage. **IF THE NOZZLE IS OPERATING CORRECTLY, THEN NO ADDITIONAL LUBRICANT IS NEEDED.** Any nozzle that is not operating correctly should be immediately removed from service.

The field use of Break Free CLP (spray or liquid) lubricant will help to restore the smooth and free operation of the nozzle. However, these lubricants do not have the washout resistance and long-term performance of the silicone grease. Therefore, re-application of Break Free CLP will be needed on a regular basis. **CAUTION:** Aerosol lubricants contain solvents that can swell O-Rings if applied in excess. The swelling can inhibit smooth operation of the moving parts. When used in moderation, as directed, the solvents quickly evaporate without adversely swelling the O-Rings.

The nozzle can be returned to the factory for a complete checkup and re-lubrication with silicone grease

#### PART ONE — COUPLING DOWN

Position the nozzle at a 45-degree angle with the COUPLING end down. CLOSE the valve handle and set the pattern to STRAIGHT STREAM. Then spray a short burst into these areas:

##### #1 FRONT PATTERN CONTROL SEAL

Spray in between the pattern control and the barrel.

##### #2 PRESSURE CONTROL UNIT

Place check sticks behind baffle while shaper is in flush. Cycle baffle in and out using check sticks several times to work lubrication into o-rings.

##### #3 FRONT SLIDER SEAL

- Rotate shaper into FLUSH position.
- Spray down the front end of the nozzle to dribble lubricant into the clearances between the shaper and the valve body.

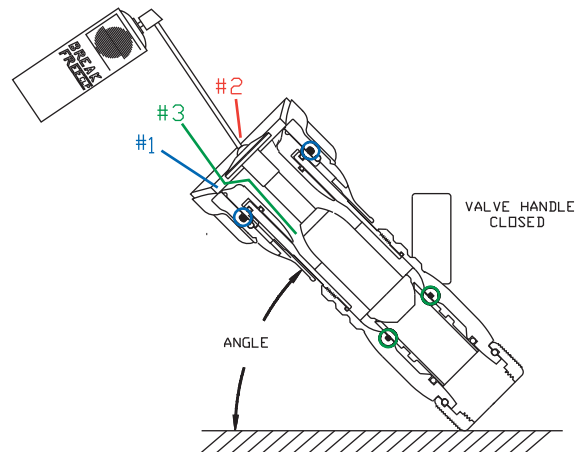

While holding nozzle at the angle, wait 30 seconds for the lubricant to penetrate into the clearances. Cycle the valve handle and rotate the shaper from straight stream to full flush several times, and then proceed to the next section.

#### PART TWO — COUPLING UP

Position the nozzle at a 45-degree angle with the BUMPER end down. OPEN the valve handle and set the pattern to FLUSH. Spray a short burst in these areas:

##### #4 REAR SHAPER SEAL

Spray down the clearance between the label and the shaper guide.

##### #5 REAR SLIDER SEAL

Spray into the clearance between the slider and the valve body.

##### #6 FLUSH MECHANISM SEAL

- With the handle on the top, spray down into the nozzle. The aerosol extension tip will help direct the spray into clearances leading to the O-Ring.
- Rotate nozzle so the valve is on the bottom and spray another short burst.

##### #7 DETENTS IN THE HANDLE

Spray a small amount on the detent followers located in the handle.

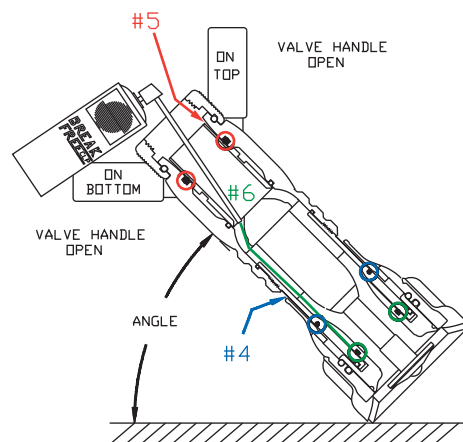

While holding nozzle at the angle, wait 30 seconds, then cycle the valve handle several times. Rotate the pattern control from straight stream to full flush several times. The pattern control should move freely and easily. The barrel cone should move forward to within 1/16" of the baffle before the shaper reaches straight stream position. Wipe off excess lubricant.

**IF THIS PROCEDURE DOES NOT RESTORE SMOOTH AND FREE OPERATION OF ALL THE MOVING PARTS, THEN FACTORY SERVICE IS NEEDED. • 24-HOUR HOT LINE — 800-348-2686 • www.tft.com**

## 11.2 IMPULSE TRIGGER VALVE LUBRICATION

- 1) Insert tube from BreakFree into drain hole in pistol grip.
- 2) With nozzle upside down spray a 2 second burst into the pistol grip. Holding a rag around the tube here can help keep excess BreakFree from the outside of the nozzle.
- 3) Keep nozzle upside down for at least 10 seconds to allow the BreakFree to flow into the valve area.
- 4) Check for smooth and free operation of the trigger. Repeat a second time if needed.

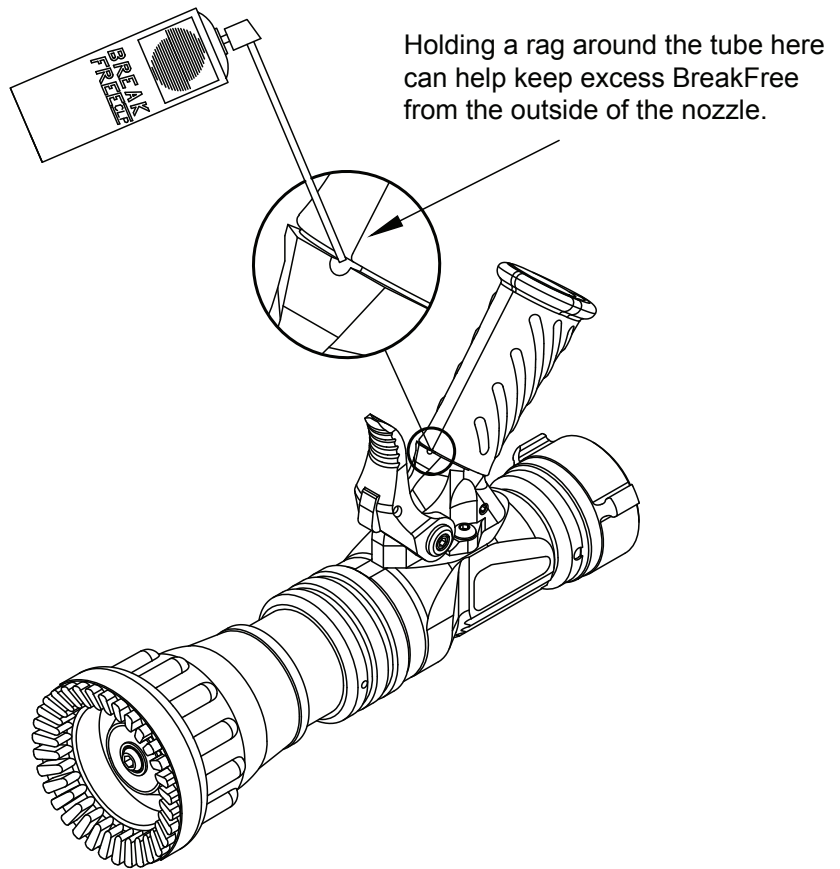

**If this procedure does not restore trigger operation then factory service is needed.  
24 hour Technical Service and Support - 800-348-2686 - [www.tft.com](http://www.tft.com)**

## 11.3 SERVICE TESTING

In accordance with NFPA 1962 (2013), nozzles must be tested a minimum of annually. Nozzles failing any part of this test must be removed from service, repaired and retested upon completion of the repair.

### 11.3.1 HYDROSTATIC TESTING

*Each nozzle with a shut off mechanism shall be tested in the following manner.*

- 1. The nozzle shall be placed in a device capable of holding it and the shut off shall be closed.*
- 2. A device capable of exerting a hydrostatic pressure of 300 psi (2070 kPa) or 1.5 times the maximum operating pressure, whichever is higher, shall be attached to the nozzle.*
- 3. All air shall be bled from the system.*
- 4. The gage pressure shall be increased by 50 psi (3.5 bar or 345 kPa) increments, held for 30 seconds at each pressure up to the maximum pressure for which the nozzle is being tested, and then held for one minute without leakage.*
- 5. There shall be no sign of leakage through the valve or shut off.*

### 11.3.2 FLOW TESTING

*Flow testing must be conducted in the following manner.*

- 1. The nozzle shall be mounted so that the flow rate and pressure through the nozzle and the pressure at the inlet can be accurately measured.*
- 2. With the shut off fully open, the inlet pressure shall be adjusted to the rated pressure  $\pm 2$  percent.*
- 3. The valve or shut off and pattern controls shall be operated through their full range of motion at 100 psi (6.9 bar or 690 kPa) with no signs of leaking, binding or other problems.*
- 4. Evaluate the flow of nozzles as defined by NFPA 1964 in the following manner:*

*Automatic (Constant Pressure) Spray Nozzles*

- 1. The flow rate shall slowly be increased to the maximum rated flow, and the minimum and maximum pressures through the flow range recorded.*
- 2. Nozzles shall maintain their rated pressure  $\pm 15$  psi ( $\pm 1$  bar or  $\pm 100$  kPa) throughout the rated flow range.*

### 11.3.3 RECORDS

A record of testing and repairs must be maintained from the time the nozzle is purchased until it is discarded. Each TFT nozzle is engraved with a unique serial number which, if so desired, can be used to identify nozzle for documentation purposes.

*The following information, if applicable, must be included on the test record for each nozzle:*

- 1. Assigned identification number*
- 2. Manufacturer*
- 3. Product or model designation*
- 4. Vendor*
- 5. Warranty*
- 6. Hose connection size*
- 7. Maximum operating pressure*
- 8. Flow rate or range*
- 9. Date received and date put in service*
- 10. Date of each service test and service test results*
- 11. Damage and repairs, including who made the repairs and the cost of repair parts*
- 12. Reason removed from service*

*NFPA 1962: Standard for the care, use, inspection, service testing, and replacement of fire hose, couplings, nozzles and fire hose appliances. (2013 ed., Section 5.5.4). Quincy, MA: National Fire Protection Agency.*

## 11.4 REPAIR

Factory service is available with repair time seldom exceeding one day in our facility. Factory-serviced nozzles are repaired by experienced technicians, wet tested to original specifications, and promptly returned. Repair charges for non-warranty items are minimal. Any returns should include a note as to the nature of the problem and whom to reach in case of questions.

Repair parts and service procedures are available for those wishing to perform their own repairs. Task Force Tips assumes no liability for damage to equipment or injury to personnel that is a result of user service. Contact the factory or visit the web site at [www.tft.com](http://www.tft.com) for parts lists, exploded views, test procedures and troubleshooting guides. All replacement parts must be obtained from the manufacturer to assure proper operation of the product, and to maintain approval of the device.

Performance tests shall be conducted on the nozzle after a repair, or anytime a problem is reported to verify operation in accordance with TFT test procedures. Consult factory for the procedure that corresponds to the model and serial number of the nozzle. Any equipment which fails the related test criteria should be removed from service immediately. Troubleshooting guides are available with each test procedure or equipment can be returned to the factory for service and testing.



**Any alterations to the nozzle and its markings could diminish safety and constitutes a misuse of this product.**

## 12.0 OPERATION AND INSPECTION CHECKLIST

**BEFORE EACH USE** the nozzle must be inspected to this checklist:

- 1) There is no obvious damage such as missing, broken or loose parts, damaged labels etc.
- 2) Debris screen is free of debris
- 3) Coupling is tight and leak free
- 4) Valve operates freely through full range and regulates flow
- 5) "OFF" position does fully shut off and flow is stopped
- 6) Nozzle flow is adequate as indicated by pump pressure and nozzle reaction
- 7) Shaper turns freely and adjusts pattern through full range
- 8) Shaper turns into full flush and out of flush with normal flow and pressure restored
- 9) Shaper detent (if so equipped) operates smoothly and positively.

**BEFORE BEING PLACED BACK IN SERVICE**, nozzles must be inspected to this checklist:

- 1) *All controls and adjustments are operational*
- 2) *Shut off valve (if so equipped) closes off the flow completely*
- 3) *There are no broken or missing parts*
- 4) *There is no damage to the nozzle that could impair safe operation (e.g. dents, cracks, corrosion or other defects)*
- 5) *The thread gasket is in good condition*
- 6) *The waterway is clear of obstructions*
- 7) *Nozzle is clean and markings are legible*
- 8) *Coupling is retightened properly*
- 9) *Shaper is set to desired pattern*
- 10) *Shutoff handle is stored in the OFF position*

*NFPA 1962: Standard for the care, use, inspection, service testing, and replacement of fire hose, couplings, nozzles and fire hose appliances. (2013 ed., Section 5.2.2). Quincy, MA: National Fire Protection Agency.*



**Any nozzle failing any part of the checklist is unsafe for use and must have the problem corrected before use or being placed back into service. Operating a nozzle that has failed the checklist is a misuse of this equipment.**